



# Architectural Lighting

Court Light Series



100W



150W



200W

GNS-FLX101D

## Product Characters :-

- Body : High quality extruded/die-cast aluminum alloy, iron sheet material complete with adjustable bracket
- Lens : Clear polycarbonate
- Gasketing : Thermostable silica gel to improve protection class
- Fastener : Stainless steel with high intensity and corrosion protection

## Applications :-

Facade, villas, parks, garden, squares, bridge etc.

## Specifications :-

Item No.	GNS-FLX101D
Power	100W   150W   200W
Voltage	AC100-240V, 50/60Hz
Color	3000K   4000K   6000K
IP Rating	IP66
Lamp Type	Philips Lumileds/CREE/NICHIA
Luminous Efficiency	≥130lm/W
Beam Angle	30°, 60°, 90°, 120°, 160°, Type I, Type II
Power Factor	≥0.95
Coloring Index (CRI)	Ra>70
LED Driver	MEANWELL
Operating Temperature	-25°C ~ 45°C
Operating Humidity	10% ~ 95%
Lifespan	>54,000 Hrs

## Dimensions (mm) :-

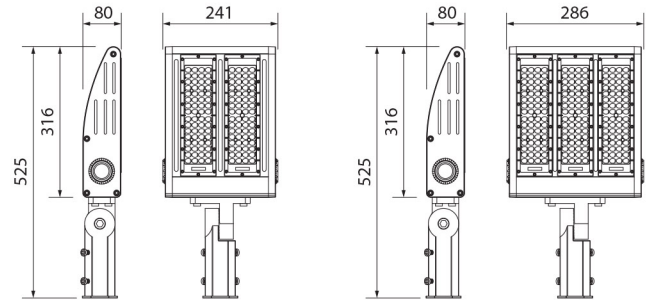

100W

150W

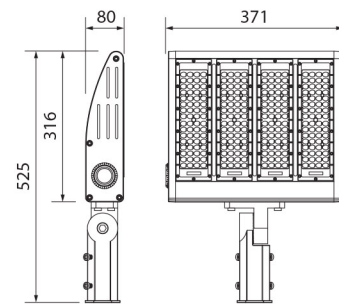

200W



# Architectural Lighting



Lens angle :-

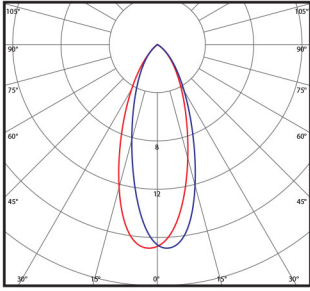

30°

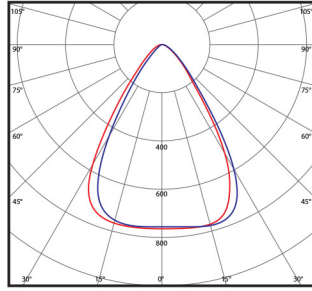

60°

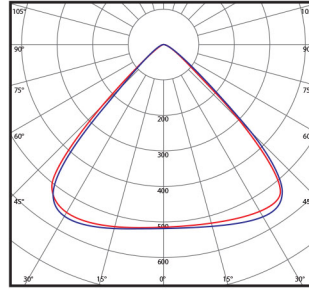

90°

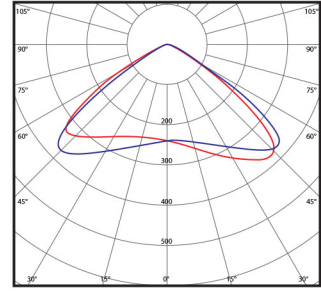

120°

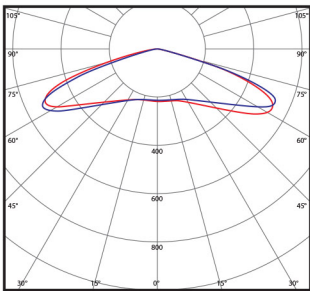

120°

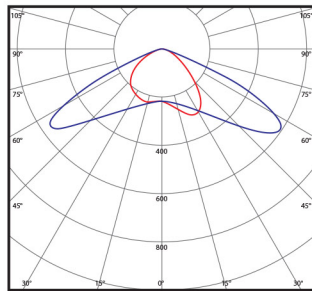

Type I

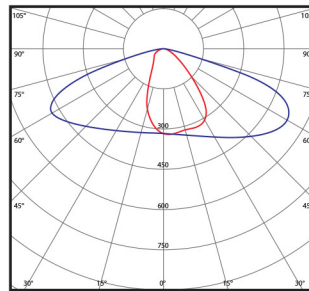

Type II

