



Architecture Lighting

Underwater Light Series

CE RoHS IP68



GNS-UW1801

Product Characteristic :-

- Body : High quality stainless steel 304 body with adjustable bracket
- Diffuser : Clear tempered glass
- Gasketing : Thermostable silica gel to improve protection class
- Fastener : Stainless steel with high intensity and corrosion protection

Application :-

Urban streets, parks, squares, garden, villas and etc.

Technical Data :-

- Insulation Class : Class I
- Standard : IEC60598/GB7000
- Protection : IP68

Specifications :-

Item No.	GNS-UW1801
Power	6W 9W 12W 15W 18W 24
LED Type	Bridgelux/Epileds/Epistar/Cree
Input Power	AC12V
Color	3000K/4000K/6000K R, B, G, Y, P - Mono
Power Factor	0.9
CRI	Ra>70
Beam Angle	5°, 8°, 15°, 25°, 30°, 45°, 60°, 90°, 120°, 10x60°, 30x45°

Dimensions (mm) :-

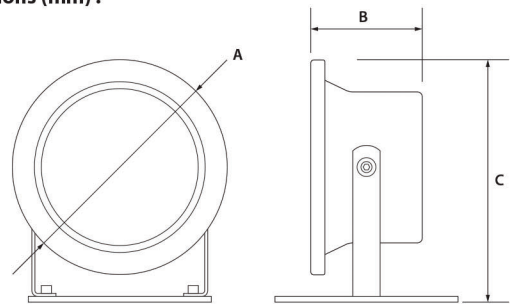

Wattage	A	B	C
6W	ø113	71	150
9W	ø133	61	153
12W/15W	ø165	75	180
18W	ø190	80	195
24W	ø212	92	223

