



LED Street Light

# Street Lighting

CE RoHS IP65



GNS-SR300

### Product Characters :-

- Body : High quality die-cast aluminum alloy
- Lens : Clear polycarbonate
- Gasketing : Thermostable silica gel to improve protection class
- Fastener : Stainless steel with high intensity and corrosion protection

### Applications :-

Streets, highways, villas, parks, garden, squares etc.

### Specifications :-

| Item No.             | GNS-SR300                                |        |
|----------------------|--|--------|
| Power                | 20W                                      | 30W    |
| Luminous Flux        | 3200lm                                   | 4800lm |
| LED Type             | Lumileds LUXEON 5050                     |        |
| Luminous Efficiency  | 160lm/W                                  |        |
| Color Temperature    | 2700K~6500K                              |        |
| IP Rating            | IP65                                     |        |
| Charging Mode        | MPPT                                     |        |
| Battery              | 12V 30AH                                 |        |
| Power Factor         | >0.95                                    |        |
| Coloring Index (CRI) | >70                                      |        |
| Solar Panel P.Max    | 30W                                      |        |
| Weight               | 5.9kg                                    |        |
| Operating Time       | Full Power>12hrs, Intelligent Mode 4-5kg |        |
| Pole Height          | 4~6M                                     |        |

### Dimensions (mm) :-

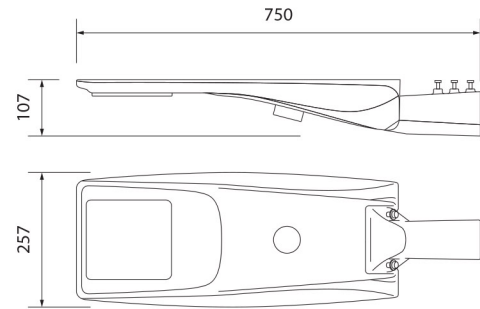

GNS-SR300

### Features :-

