

STREET LANTERN



GNS-LT011



Product Characters :-

- Body : High quality die-cast aluminum alloy
- Lens : Clear polycarbonate
- Gasketing : Thermostable silica gel to improve protection class
- Fastener : Stainless steel with high intensity and corrosion protection
- Circuit Protection : Power Supply with Over Voltage Protection, Short Circuit Protection, and Over Current Protection. Light Source with Over Temperature Protection

Applications :-

Streets, highways, villas, parks, garden, squares etc.

Specifications :-

Item No.	GNS-LT011
Power	180W 200W
LED Type	Philips/Osram
Voltage	AC90-305V, 50/60Hz
Luminous Flux	180W : 21600lm 200W : 23325lm
Luminous Efficiency	180W : 120lm/W 200W : 116lm/W
Color Temperature (CCT)	3000K/4000K/6500K
Coloring Index, CRI	>65
Power Factor	>0.98
Beam Angle	150° x 70°
Driver	Meanwell HLG
Working Temp.	-20°C ~ 50°C
Operating Humidity	10% ~ 90% RH
Protection Class	IP66
Lifespan	50,000 Hrs
Material	Aluminum / PC

Dimensions (mm) :-

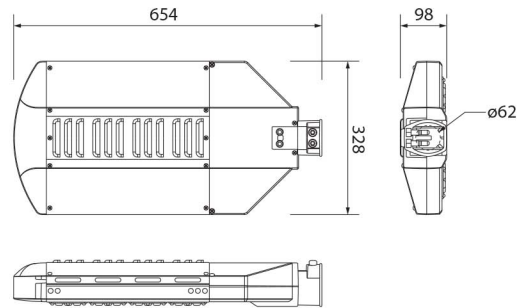

GNS-LT011

Photometric Data :-

