

SOLAR LED LANTERN



GNS-SR010

Product Characters :-

- Body : High quality die-cast aluminum alloy
- Lens : Clear polycarbonate
- Gasketing : Thermostable silica gel to improve protection class
- Fastener : Stainless steel with high intensity and corrosion protection
- Circuit Protection : Power Supply with Over Voltage Protection, Short Circuit Protection, and Over Current Protection. Light Source with Over Temperature Protection

Applications :-

Streets, highways, villas, parks, garden, squares etc.

Specifications :-

LANTERN	
Item No.	GNS-SR010
Power	30W 50W
LED Type	Philips SMD LED
Luminous Flux	30W : >4200lm 50W : >6800lm
Luminous Efficiency	30W : >140lm/W 50W : >136lm/W
Color Temperature (CCT)	3000K/4000K/6500K
Coloring Index, CRI	>82
Power Factor	>0.95
Beam Angle	140° x 70°
Battery Capacity	30W : 35.2AH, 11.1V 50W : 49.3AH, 11.1V
Charging Mode	MPPT
Protection Class	IP67

SOLAR PANEL	
Voltage of PV	DC18V
Power of PV	80W 100W
Cell of PV	MONOCell
Pole Height	30W : 3-6M 50W : 4-8M

Dimensions (mm) :-

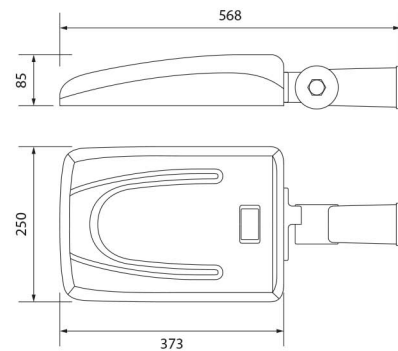

Features :-



MC4 Connector



Lithium Battery



Microwave Sensor



Philips SMD LED

