



GNS-LT012



Product Characters :-

- Body : High quality die-cast aluminum alloy
- Lens : Clear polycarbonate
- Gasketing : Thermostable silica gel to improve protection class
- Fastener : Stainless steel with high intensity and corrosion protection
- Circuit Protection : Power Supply with Over Voltage Protection, Short Circuit Protection, and Over Current Protection. Light Source with Over Temperature Protection

Applications :-

Streets, highways, villas, parks, garden, squares etc.

Specifications :-

Item No.	GNS-LT012
Power	60W 90W 120W 150W 180W 200W
LED Type	Bridgelux 26*30mil(8C1B)
Voltage	AC90-305V, 50/60Hz
Luminous Flux	60W : 7500lm 90W : 11070lm 120W : 15012lm 150W : 18765lm 180W : 22518lm 200W : 24720lm
Luminous Efficiency	123-125lm/W
Color Temperature (CCT)	3000K/4000K/6500K
Coloring Index, CRI	>70
Power Factor	>0.95
Beam Angle	150° x 70°
Power Efficiency	88%
Working Temp.	-40°C ~ 50°C
Operating Humidity	20% ~ 90% RH
Protection Class	IP66
Lifespan	50,000 Hrs
Material	Aluminum / PC

Dimensions (mm) :-

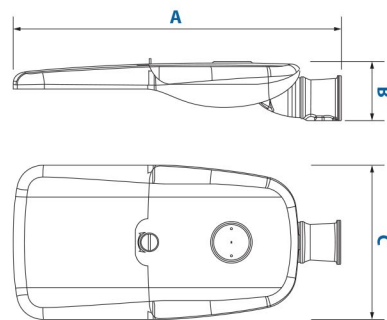

	A	B	C
60W	524	110	251
90W	590	110	281
120W	692	116	337
150W	692	116	337
180W	692	116	337
200W	692	116	337

Photometric Data :-

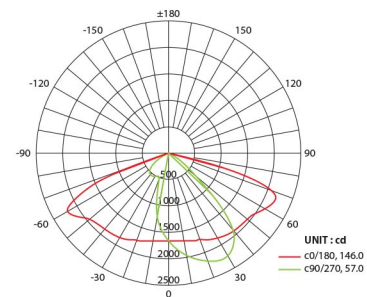

AVERAGE BEAM ANGLE (50%) : 101.5 DEG